

INSTALLATION GUIDE

Extract 295

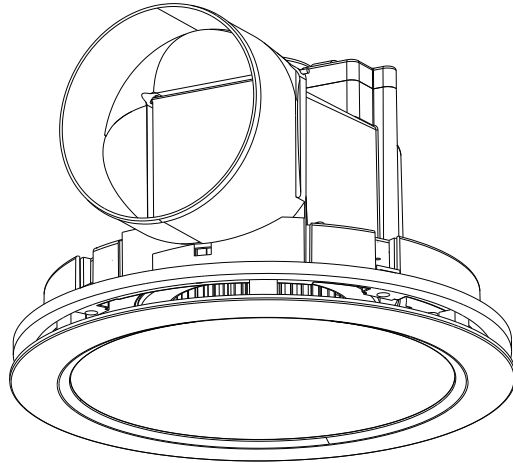

Product Code:

4S6003WH Extract Round 295mm Exhaust Fan Matt White with 17W Tricolour LED Light

CAUTION
READ INSTRUCTIONS
CAREFULLY FOR SAFE
INSTALLATION AND FAN
OPERATION



**MUST BE
INSTALLED BY
A LICENSED
ELECTRICIAN**

SAFETY PRECAUTIONS

We strongly recommend that you read this manual carefully before installation. Installation MUST carry out by a qualified and licensed electrician.

NB: This product is for indoor installation only.

- Unit must be installed into a horizontal location, not suitable for wall mount or raked ceilings
- Check ceiling cavity for hidden beams, structures and concealed electrical cabling prior to installation
- Unit should not be installed directly above shower or bath cubicles or in any location where splashed water can contact the unit, or the switch can be reached and turned on by someone within a bath or shower
- Position fan in a central location to maximise ventilation to all areas
- Ensure air is ventilated to an outside location (not into roof cavities) via the use of a duct/grill assembly which is not supplied
- Do not install the exhaust fan within 1m distance from a ceiling or wallmounted heat source
- Exhaust fans may adversely affect the safe operation of appliances burning gas or other fuels (including those in other rooms) due to back flow of combustion gases. These gases can potentially result in carbon monoxide poisoning. After installation of an exhaust fan such as a partition fan or a duct fan the operation of open flued gas appliances should be tested by a competent person to ensure that back flow of combustion gases does not occur
- The minimum clearance distance from the top of the luminaire to any normally flammable building element is 100mm
- The minimum clearance distance from the top of the luminaire to any normally flammable building insulation is 100mm
- The minimum clearance distance from the side of the luminaire to any normally flammable building element is 250mm
- The minimum clearance distance from the side of the luminaire to any normally flammable building insulation is 250mm

Capacity Disclaimer

All capacity figures and technical data provided herein are sourced from the manufacturer. The capacity figures are based on the unit operating in a free-flowing state (not connected to ducting). If you intend to connect this unit to ducting, it is advisable to maintain the duct run as short, straight, and tight as possible.

PLEASE NOTE: Check for any damage to the unit prior to installation.

Physical damage such as marks and scratches are not covered by the in-home warranty.

In this case, please contact the Four Seasons support team to discuss replacement parts.

INSTALLATION

NB: Installation MUST be carried out by a qualified and licensed electrician.

Step 1. Turn OFF mains power

Step 2. Ensure location instructions (see pg.2) are followed

Step 3. Mark and cut a Ø295mm hole into the ceiling using proper tools such as plaster saw, jigsaw or holesaw

NB: Highly recommend to wear safety glasses to avoid fall from the ceiling into the eyes.

Step 4. If ducting is required for ventilation, install a 150mm duct pipe to the exhaust fan and lay the ducting across the ceiling and onto a suitable 150mm exhaust vent (see figure 1)

Step 5. Plug the cable into the power point socket in the ceiling (see figure 2)

Step 6. Position fan in hole, rotate mounting screws with a screwdriver until slip blocks firmly secure fan onto ceiling plaster. Do not over tighten (see figure 3)

Step 7. Replace external cover over fan blades by locating spring hole slots and allowing springs to pull the cover plate up over the fan and onto the ceiling surface

NB: Please ensure yellow label “Tear this seal before using or installing” is removed from the unit.

Step 8. Turn ON mains power

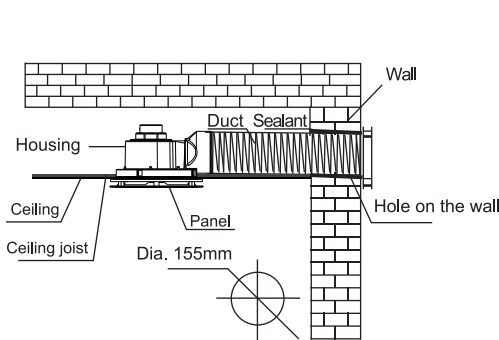

Figure 1: Installing ducting (sold separately)

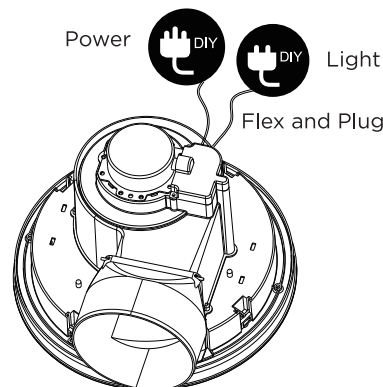

Figure 2: Connect the power and light

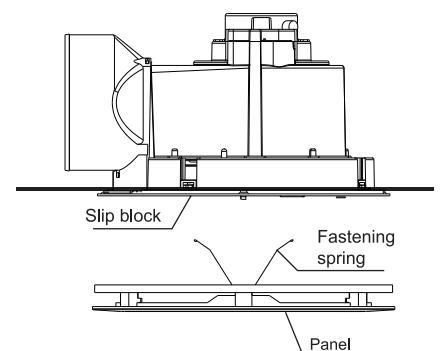
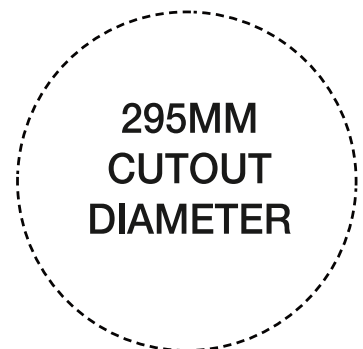
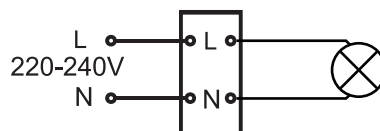
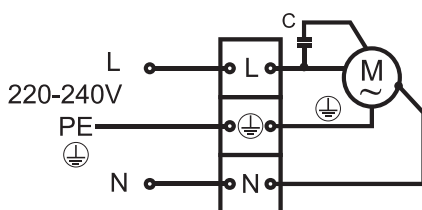

Figure 3: Fix the fan in place and install cover

Wiring Diagram



IMPORTANT NOTICES

WARNING

- Installation of bathroom heater and exhaust fan MUST follow SAA standards and meet local authority regulations
- **WARNING - RISK OF OVERHEATING OR FIRE IF THE CLEARANCE DISTANCES ARE COMPROMISED**
- Installation MUST be carried out by a qualified and licensed electrician
- Bathroom heater and exhaust fan MUST NOT be installed under any electrical outlet
- Bathroom heater and exhaust fan MUST NOT be installed near curtains or other combustible materials
- Joists, beams and rafters MUST NOT be cut or notched to install the product
- DO NOT attempt to open and repair the product
- The warranty is VOID if product is not installed according to this installation guide
- The appliance is not to be used by persons (including children) with reduced physical, sensory or mental capabilities, or lack of experience and knowledge, unless they have been given supervision or instruction
- Children being supervised not to play with the appliance
- The light source contained in this luminaire shall only be replaced by the manufacturer or his service agent or a similar qualified person

CARE & MAINTENANCE

- The product must be turned OFF and cool before cleaning
- To clean the fascia simply use a dampened cloth

WARRANTY INFORMATION

For technical support, please contact Four Seasons customer service hotline at **(02) 8778 7570**.

If you suspect any issues with the installation, please contact your installer to resolve the matter. In case you believe the issue is related to a manufacturing defect, you can file a warranty claim by visiting <https://fourseasonsliving.com.au/warranty-claim-form/> or scan below QR code.

IMPORTANT NOTICE: All claims for warranty must be accompanied with the following three documents:

1. Copy of the Installation Receipt OR Tax Invoice OR Certificate of Compliance for the installation of the Four Seasons product from the installing electrician.
2. Copy of the Purchase Receipt for the Four Seasons product, and accessories.
3. Submit an online warranty claim form. Please ensure that the purchaser's full name and contact details are clearly stated, in addition to the full nature of the fault and the serial or P.O. number.

It is the responsibility of the purchaser to keep the documents required for a warranty application for the duration of the warranty period.

Customer Service operates between 8AM to 4PM EST Monday to Friday.
Customer Service Number: **(02) 8778 7570**

